

Schäffer Lader

PREMIUM CLASS

2028	2033	2336	2345
3345	3350	3450	3460
4350	4360	4160	5370



**THE GERMAN-ENGINEERED
COMPACT EXTRA POWER LOADERS
WITH ERGONOMICS AND FLEXIBILITY**

YARD LOADERS, WHEEL LOADERS AND TELESCOPIC LOADERS ...

from 14 kW (20 HP) to 130 kW (177 HP). At SCHÄFFER Loaders, we have a proud 50 year history of creating loaders for individual requirements. Our customers have made us what we are today: one of the world's most competitive and successful suppliers of yard loaders, wheel loaders and telescopic loaders. Every day our team creates new custom solutions that combine years of experience with a spirit of innovation. Our products set industry standards for reliability and durability, which means you save with lower servicing costs over the life of your vehicle. The Schäffer name is your assurance of superior performance, safety and comfort for years to come.



2028 | 19 kW (26 HP)

2336 | 26 kW (36 HP)

3345 | 33 kW (45 HP)

3350 | 37 kW (50 HP)

2033 | 24 kW (33 HP)

2345 | 33 kW (45 HP)

3360 | 44 kW (60 HP)

THE EXTRA CLASS OF SCHÄFFER: POWER, ERGONOMICS AND FLEXIBILITY

Whatever you want to move, you need the right machine for the job. Working effectively often means getting a little creative to achieve peak productivity. SCHÄFFER loaders are made to work in an easy yet cost-efficient way – with a flexibility that only SCHÄFFER offers. For example, you can choose from an optional ROPS-bar, a hardtop or, for the ultimate in driver comfort, a comfort cab – all available on the very compact 2033. And when it's time to choose your working tools, things really get exciting. Whatever you need technically, we can put together a customised vehicle for you.



3450 | 37 kW (50 HP)

3460 | 44 kW (60 HP)

4350 Z | 37 kW (50 HP)

4360 Z | 44 kW (60 HP)

4160 | 44 kW (60 HP)

5370 Z | 51 kW (70 HP)

5390 Z | 63 kW (86 HP)

CLEAR VISIBILITY ...

You can really see what you're doing when you drive a SCHÄFFER. Front visibility is excellent thanks to the narrow, conical loading arm. Your vision is also enhanced by the hydraulic cylinders, positioned centrally in the loading arm. As with all hydraulic cylinders these are freely suspended with ball jointed bearings instead of fixed pins or bearing bushes so they will give you trouble-free operation for years.



EVERYTHING SIMPLY WORKS ...

This is what a driver's cockpit should look like. The driver has total control over everything while enjoying excellent visibility. The steering column and seat are fully adjustable to suit the individual operator. Ergonomics is not an end in itself but designed to achieve maximum productivity.



Schäffer Lader

COMFORT AND SAFETY? IT'S YOURS ...

All Schäffer's articulated pendulum joints are totally maintenance-free. Doing away with daily lubrication dramatically reduces your workload. Even more importantly, the joints are virtually indestructible. That's why we offer you a warranty on this component of 3 years or 3000 operating hours. SCHÄFFER loaders are so tough they just keep going, yet they are also extremely agile and manoeuvrable.



The SCHÄFFER
4160 in action.

POWER THAT KEEPS GOING ALL YEAR ...

You expect technology that delivers both economy and driver comfort, no matter what conditions. With a SCHÄFFER, the hydrostatic drive works brilliantly whatever the demands. The speed can be adjusted automatically to suit various situations without compromising pushing power. The driver always has control, with economy and ergonomics guaranteed. An efficient hydraulic system is the key to an efficient machine and Schäffer's hydraulics can be fine-tuned to do any job with ease. We can even tailor your loader's hydraulics to suit your specific needs in our factory.



For all hydrostatically driven machines, the brake/ inch pedal comes as standard equipment. On request, a continuously variable, electro-proportional speed adjustment is also available.

KUBOTA MOTOR TECHNOLOGY ...

SCHÄFFER has worked in partnership with Kubota, a leading manufacturer of compact diesel motors, for more than 25 years. Kubota has an unsurpassed reputation for quality all over the world. Even in freezing temperatures a Kubota motor will start with ease. You can sense safety and power in the way it sounds, and its excellent torque delivers exceptional performance. Forget maintenance problems – you can expect around 10,000 hours of trouble-free operation. Kubota motors are also exceptionally economical, fuel-efficient and environmentally friendly. A unique prechamber system means a motor can easily be converted to cold-pressed vegetable oil without the need for a separate diesel fuel tank. Kubota motors are future-proof!

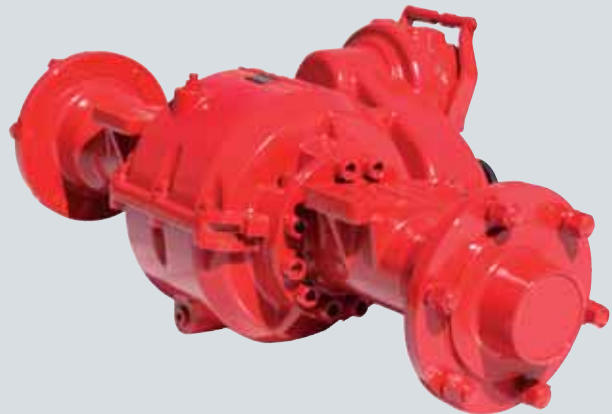

ORIGINAL SCHÄFFER AXLES - NO END OF PUSHING POWER ...

Original SCHÄFFER axles are adjusted 100% to each particular loader – that's the secret of their outstanding pushing power, as proved by independent tests. Safety is another important benefit of SCHÄFFER axles. From model 3345, the permitted load bearing capacity is 7t per axle. From model 2033, all loaders are equipped with an oil-immersed, capsuled, multi-disc brake. These are brakes you can always count on! Not only do they deliver optimal deceleration values, they are also totally maintenance-free. Dirt, dust and humidity don't stand a chance.



ROBUST, POWERFUL TECHNOLOGY

Do you need to transfer bulk goods and transport heavy loads? The SCHÄFFER 5300 series wheel loaders are made for this. The Z-kinematic has a powerful grabbing action, and the ability to lift and tip over loads with ease. At the same time, the freely suspended rear axle greatly increases the machine's durability and stability.



Schäffer Lader



COMPUTER OPTIMIZED LOADING ARM WITH Z-KINEMATICS - SIMPLY STRONG

Do you want maximum break-out and lifting forces? SCHÄFFER delivers. Our expert engineers use the latest in three-dimensional computer-aided design, optimised by years of experience. The result is superior visibility to the front: tapering from narrower at the mount to wider at the tool. Even for demanding tasks, a SCHÄFFER is everything you could ask for and more. Half a century of expertise pays off!



The 4350Z, with an operating weight of just over 3,5t, is a great mid-range machine. It's easy to load even the biggest trailers thanks to a lifting height of 3,26 m. The hardtop can be equipped with a front and rear window as an alternative to the comfort cabin. Powerful Kubota motors with 37 kW (50 HP) or 44 kW (60 HP) drive the machine. The steady under load, switchable high speed gear (20 km/h) is standard.

TECHNICAL DATA

	2028	2033	2336	2345	3345
Engine	3 cyl. Kubota 19 kW (26HP)	3 cyl. Kubota 24 kW (33 HP)	4 cyl. Kubota 26 kW (36 HP)	4 cyl. Kubota Turbo 33 kW (45 HP)	4 cyl. Kubota Turbo 33 kW (45 HP)
Driving hydraulics	hydrostatic automotive	hydrostatic automotive	hydrostatic automotive	hydrostatic automotive	hydrostatic automotive
Tyres	7.00 - 12 AS Option I 27x8.50-15 Option II 27x10.50-15 Option III 26x12.00-12	10.075 - 15.3 AS Option I 27x10.5 - 15 Option II 31x15.5 - 15	10.075 - 15.3 AS Option I 27x10.5 - 15 Option II 31x15.5 - 15	10.075 - 15.3 AS Option I 27x10.5 - 15 Option II 31x15.5 - 15	10.075 - 15.3 AS Option I 11.5/80 - 15.3 AS Option II 31x15.5 - 15 Option III 15.0/55 - 17 Option IV 425/55 R17
Service brake	hydrostatic/mechanical	combined brake hydrostatic and multi-disc brake	combined brake hydrostatic and multi-disc brake	combined brake hydrostatic and multi-disc brake	combined brake hydrostatic and multi-disc brake
Parking brake	mechanical drum brake	oil-immersed multi-disc brake	oil-immersed multi-disc brake	oil-immersed multi-disc brake	oil-immersed multi-disc brake
Working hydraulics	Pump output: 33 l/min	Pump output: 42 l/min	Pump output: 42 l/min	Pump output: 42 l/min	Pump output: 48 l/min
Steering hydraulics	Working pressure: 200 bar	Working pressure: 200 bar	Working pressure: 200 bar	Working pressure: 200 bar	Working pressure: 200 bar
Steering	fully hydraulic articulated steering system	fully hydraulic articulated steering system	fully hydraulic articulated steering system	fully hydraulic articulated steering system	fully hydraulic articulated steering system
Lifting capacity	1,500 kg	1,600 kg	1,700 kg	1,700 kg	1,900 kg
Tipping load (straight)	920 kg	1,000 kg	1,200 kg	1,300 kg	1,650 kg
Tipping load (articulated)	550 kg	720 kg	900 kg	930 kg	1,250 kg
Axles	original Schäffer axles 4 wheel nut rim	Original Schäffer axles 5 wheel nut rim, Option: automatic limited-slip differential	Original Schäffer axles 6 wheel nut rim, Option: automatic limited-slip differential	Original Schäffer axles 6 wheel nut rim, Option: automatic limited-slip differential	Original Schäffer axles 6 wheel nut rim, Option: automatic limited-slip differential
Working weight	1,750 kg	1,880 kg/2,080 kg with cab	2,200 kg/2,400 kg with cab	2,200 kg/2,400 kg with cab	2,550 kg/2,750 kg with cab
Speed	0 - 15 km/h	0 - 15 km/h	0 - 15 km/h, Option: 0 - 20 km/h 2 speeds gear switching under load possible	0 - 20 km/h 2 speeds gear switching under load possible	0 - 20 km/h in 2 speeds gear switching under load possible
Electrical system	operating voltage 12 V	operating voltage 12 V	operating voltage 12 V	operating voltage 12 V	operating voltage 12 V
Tank capacities	fuel: 23 l hydraulic fluid: 30 l	fuel: 40 l hydraulic fluid: 30 l	fuel: 40 l hydraulic fluid: 30 l	fuel: 40 l hydraulic fluid: 30 l	fuel: 55 l hydraulic fluid: 50 l

	3350 / 3360	3450 / 3460	4350 Z / 4360 Z	4160	5370 Z / 5390 Z
Engine	4 cyl. Kubota 4 cyl. Kubota Turbo 37 kW (50 HP) 44 kW (60 HP)	4 cyl. Kubota 4 cyl. Kubota Turbo 37 kW (50 HP) 44 kW (60 HP)	4 cyl. Kubota 4 cyl. Kubota Turbo 37 kW (50 HP) 44 kW (60 HP)	4 cyl. Kubota Turbo 44 kW (60 HP)	4 cyl. Kubota 4 cyl. Kubota Turbo 51 kW (70 HP) 63 kW (86 HP)
Driving hydraulics	hydrostatic automotive	hydrostatic automotive	hydrostatic automotive	hydrostatic automotive	hydrostatic automotive
Tyres	10.075 - 15.3 AS Option I 11.5/80 - 15.3 AS Option II 31x15.5 - 15 Option III 15.0/55 - 17 Option IV 425/55 R17	10.075 - 15.3 AS Option I 11.5/80 - 15.3 AS Option II 31x15.5 - 15 Option III 15.0/55 - 17 Option IV 425/55 R17	11.5/80 - 15.3 AS Option I 15.0/55 - 17 AS Option II 425/55 R17	11.5/80 - 15.3 AS Option I 15.0/55 - 17 AS Option II 425/55 R17	15.0/55-17 AS Option I 500/45-20 AS Option II 425/55 R17
Service brake	combined brake hydrostatic and multi-disc brake	combined brake hydrostatic and multi-disc brake	combined brake hydrostatic and multi-disc brake	combined brake hydrostatic and multi-disc brake	combined brake hydrostatic and multi-disc brake
Parking brake	oil-immersed multi-disc brake	oil-immersed multi-disc brake	oil-immersed multi-disc brake	oil-immersed multi-disc brake	oil-immersed multi-disc brake
Working hydraulics	Pump output: 48 l/min	Pump output: 48 l/min	Pump output: 70 l/min	Pump output: 70 l/min	Pump output: 70 l/min
Steering hydraulics	Working pressure: 200 bar	Working pressure: 200 bar	Working pressure: 200 bar	Working pressure: 200 bar	Working pressure: 200 bar
Steering	fully hydraulic articulated steering system	fully hydraulic articulated steering system	fully hydraulic articulated steering system	fully hydraulic articulated steering system	fully hydraulic articulated steering system
Lifting capacity	2,000 kg	2,100 kg	2,400 kg	2,700 kg	2,800 kg/2,800 kg
Tipping load (straight)	1,800 kg	1,850 kg	2,200 kg	2,150 kg	2,600 kg/2,750 kg
Tipping load (articulated)	1,400 kg	1,300 kg	1,700 kg	1,650 kg	2,250 kg/2,400 kg
Axles	Original Schäffer axles 6 wheel nut rim, Option: automatic limited-slip differential	Original Schäffer axles 6 wheel nut rim, Option: automatic limited-slip differential	Original Schäffer planetary axles 6 wheel nut rim, with automatic limited-slip differential	Original Schäffer planetary axles 6 wheel nut rim, with automatic limited-slip differential	Original Schäffer planetary axles 6 wheel nut rim, with automatic limited-slip differential
Working weight	2,700 kg/2,900 kg with cab	2,500 kg/2,700 kg with cab	3,400 kg/3,520 kg with cab	3,300 kg/3,480 kg with cab	hardtop: 4,150 kg/4,520 kg cabine: 4,300 kg/4,670 kg
Speed	0 - 20 km/h 2 speeds gear switching under load possible	0 - 20 km/h 2 speeds gear switching under load possible Option: 0 - 30 km/h	0 - 20 km/h 2 speeds gear switching under load possible Option: 0 - 30 km/h	0 - 20 km/h 2 speeds gear switching under load possible Option: 0 - 30 km/h	0 - 20 km/h 2 speeds gear switching under load possible Option: 0 - 30 km/h
Electrical system	operating voltage 12 V	operating voltage 12 V	operating voltage 12 V	operating voltage 12 V	operating voltage 12 V
Tank capacities	fuel: 55 l hydraulic fluid: 50 l	fuel: 55 l hydraulic fluid: 50 l	fuel: 90 l hydraulic fluid: 60 l	fuel: 90 l hydraulic fluid: 60 l	fuel: 65 l hydraulic fluid: 60 l

DIMENSIONS

Schäffer Lader

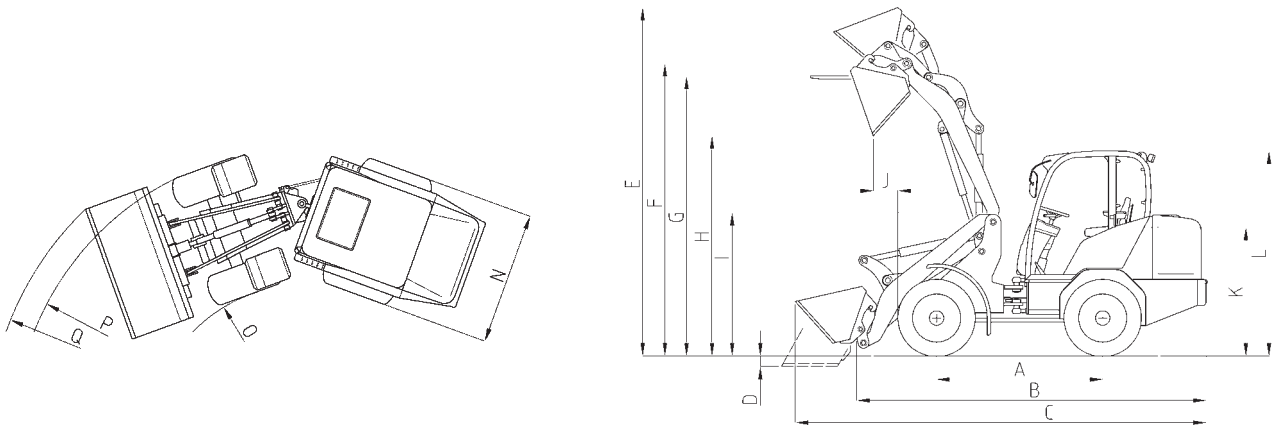

		2028	2033	2336	2345	3345	3350 3360	3450 3460	4350 Z 4360 Z	4160	5370 Z 5390 Z
A	Wheel base [mm]	1.375	1.410	1.550	1.550	1.730	1.730	1.830	2.000	2.000	1.930
B	Chassis length [mm]	2.780	2.930	3.085	3.085	3.485	3.485	3.585	4.050	3.840	4.480
C	Total length with standard bucket [mm]	3.530	3.610	3.800	3.800	4.185	4.185	4.095	4.730	4.500	5.250
D	Digging depth [mm]	110	110	90	90	90	90	90	120	130	180
E	Max. working height [mm]	3.460/3.720**	3.540/3.770**	3.570/3.800**	3.570/3.800**	3.550/3.800**	3.550/3.800**	3.150	4.060	3.320	4.070
F	Max. bucket pivot point [mm]	2.800/3.060**	2.880/3.110**	2.880/3.110**	2.880/3.110**	2.950/3.200**	2.950/3.200**	2.500	3.260	2.750	3.400
G	Max. loading height with pallet fork [mm]	2.560/2.920**	2.640/2.970**	2.680/3.100**	2.680/3.100**	2.810/2.940**	2.810/2.940**	2.400	3.050	2.610	3.175
H	Max. load over height [mm]	1.965/2.265**	2.045/2.300**	2.045/2.300**	2.045/2.300**	2.140/2.390**	2.140/2.390**	1.700	2.500	1.950	2.700
I	Max. dump height [mm]	1.600/1.725**	1.680/1.780**	1.690/1.790**	1.690/1.790**	1.700/1.790**	1.700/1.790**	1.550	1.570	1.650	1.640
J	Dump range [mm]	440	440	470	470	560	560	510	640	350	600
K	Seat height [mm]	1.055	1.160	1.160	1.160	1.150	1.150	1.150	1.270	1.270	1.340
L	Rollover bar height (folded) [mm]	1.770	1.800	-	-	-	-	-	-	-	-
	Height ROPS-bar/folded [mm]	2.150/1.775	2.250/1.875	2.280/1.780	2.280/1.780	2.360/1.820	2.360/1.820	2.360/1.820	2.360/1.820	2.360/1.820	2.645/2.120
	Height with protective roof [mm]	2.040	2.135	2.215	2.215	2.240	2.240	2.240	-	-	-
	Height with cabin/hardtop [mm]	-	2.140	2.110	2.110	2.200	2.200	2.200	2.270	2.200	2.320
N	Total width [mm]	885 – 1.240	1.020-1.390	1.020-1.390	1.020-1.390	1.020-1.540	1.020-1.540	1.020 – 1.540	1.230-1.600	1.230-1.600	1.420 – 1.800
O	Smallest turn (outer edge tire) [mm]	660	580	800	800	1.100	1.100	1.100	1.450	1.310	1.670
P	Smallest turn (innerr edge tire) [mm]	1.560	1.600	1.820	1.820	2.120	2.120	2.120	2.680	2.540	3.090
Q	External radius with standard bucket [mm]	1.950	1.950	2.250	2.250	2.500	2.500	2.500	3.010	2.870	3.750

** with high lift





The way SCHÄFFER loaders are developed, built and serviced is unique. The difference is our 50 years of experience. First, we think about the operator; we want to make his work safer, more comfortable – and more profitable. To this end, we are equipped with the most modern development and production technologies at our plant in Erwitte, Germany. Ultimately, it is our associates who work with our customers to continuously develop new solutions. Long years of commitment to the company combined with an enduring spirit of innovation are the basis of our exceptional worldwide success.

The name SCHÄFFER Loaders stands for more than one-of-a-kind product quality. It also stands for safety and optimal service, which we guarantee not only in Germany but around the globe.

The purchase of a SCHÄFFER loader is the beginning of a long-term relationship. Only original replacement parts allow your machine to remain a 100% true SCHÄFFER over the years. Only then will it guarantee the reliability you rightly expect. We offer you and our service partners a 24 hour delivery service – 7 days a week, 365 days a year.

made by SCHÄFFER

SCHÄFFER offers you a product line-up of over 40 different models, each of which can be adapted to your individual requirements. Our loaders can be used in many different industries: in agriculture or construction, in horticulture or landscaping, in industry and trade, in horse husbandry or warehousing. Whatever the industry, SCHÄFFER is always your first choice.



Schaeffer Lader

Your Dealer:

SCHÄFFER MASCHINENFABRIK GMBH

Postfach 10 67 | D-59591 Erwitte

Phone +49 02943 9709-0

Fax +49 02943 9709-50

info@schaeffler-lader.de

www.schaeffler-lader.de